

(No Model.)

A. D. QUINT.

AUTOMATIC REVERSING MECHANISM FOR TOOL HOLDERS.

No. 564,223.

Patented July 21, 1896.

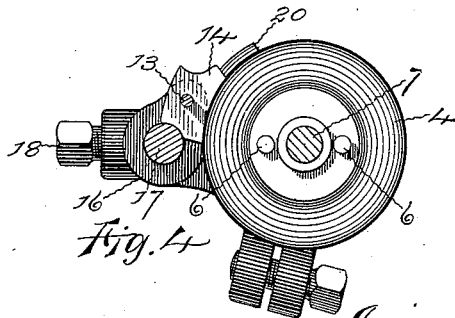
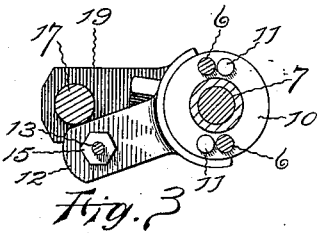
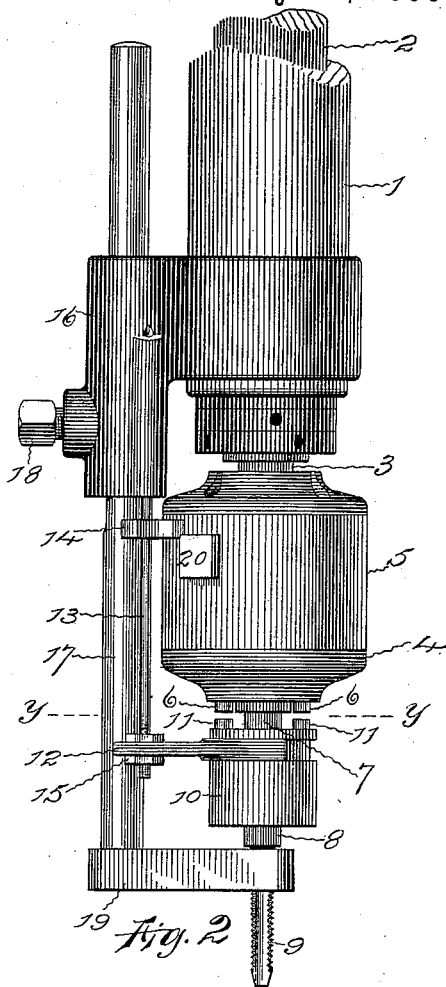
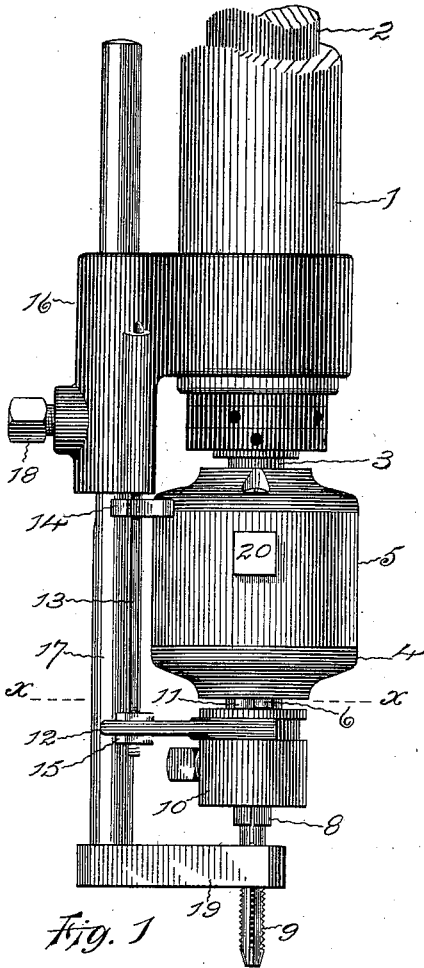

Witnesses:

E. J. Hyde,  
C. E. Buckland.

Inventor:

Alanson D. Quint by  
Harry R. Williams  
att.

# UNITED STATES PATENT OFFICE.

ALANSON D. QUINT, OF HARTFORD, CONNECTICUT.

## AUTOMATIC REVERSING MECHANISM FOR TOOL-HOLDERS.

SPECIFICATION forming part of Letters Patent No. 564,223, dated July 21, 1896.

Application filed April 16, 1896. Serial No. 587,820. (No model.)

*To all whom it may concern:*

Be it known that I, ALANSON D. QUINT, a citizen of the United States, residing at Hartford, in the county of Hartford and State of Connecticut, have invented certain new and useful Improvements in Automatic Reversing Mechanism for Tool-Holders, of which the following is a specification.

The invention relates to a device which can be used, in connection with a lathe or with a drill-press or drilling-machine, for holding a cutting, boring, drilling, or tapping tool, as the case may be, in such manner that the direction of rotation of the tool may be changed without changing the direction of rotation of the driving-spindle.

The object of the invention is to provide a simple device of this class with means which can be so adjusted and set that at any predetermined time the direction of rotation of the tool will automatically be reversed without changing the direction of rotation of the driving-spindle.

To this end the invention resides in a device having a tool holder or chuck that is loosely held by a head intended to be rotated by the live-spindle of the lathe or drill, the connection between the head and the tool-holder being such that the tool-holder when in one position is positively clutched by the head and rotates with it in the same direction, but when in its other position will be rotated by intermediate mechanism that is supported by the head, in a reverse direction from the direction of the rotation of the head, with a dog connected to and movable with the tool-holder, so as to engage with and bring into operation or disengage from and stop the operation of the intermediate reverse rotating mechanism, and a trip device or foot which can be so adjusted that at the desired moment the tool-holder and the connected dog will be caused to make the proper connections for reversing the direction of rotation of the tool, as more particularly hereinafter described, and pointed out in the claims.

Referring to the accompanying drawings, Figure 1 is a side view of the mechanism arranged as applied to the head and spindle of a vertical drill, showing the relative position occupied by the parts when a hole is being tapped. Fig. 2 is a similar view with the

parts shown in the position occupied when the tap is running in a reverse direction to unscrew from a perforation which has been threaded. Fig. 3 is a sectional view taken on the plane indicated by the broken line X X of Fig. 1, looking downward; and Fig. 4 is a sectional view taken on the plane Y Y of Fig. 2, looking upward.

In the views, 1 indicates a section of a head-stock of a lathe or the sleeve of a drill-press or other stationary part of a drilling-machine in which the ordinary live-spindle of such a machine is rotarily supported. In these views the sleeve is shown standing vertically, as if broken from a part of a drill-press, but it can, of course, be arranged horizontally as well as vertically.

In the usual opening in the end of the live-spindle 2 is thrust and held in a common manner the tapering shank 3 of a reversing tap-holder. The reversing tap-holder illustrated is of a common form and can be obtained in the market. It has a head 4 with a loose sleeve 5 and the projecting clutch-pins 6 and the interior gears, as shown in United States Letters Patent No. 531,382, dated December 25, 1894.

The head supports the shaft 7, that bears the tool holder or chuck 8, which in the drawings is holding an ordinary tap 9. This shaft 7 is illustrated as provided with a collar 10 with projecting clutch-pins 11, adapted to make contact with the pins 6, projecting from the head. The shaft is arranged to move a limited distance longitudinally into and out of the head, and when moved into the head the pins 6 and the pins 11 engage, as shown in Fig. 1. When in this position, the shaft, head, and sleeve will rotate as one part, the spindle rotating the head, and the head, through the clutch-pins, rotating the shaft with the tool-holder, so that the tool will rotate in the same direction as the live-spindle. With the shaft drawn out from the head the pins are disengaged, as shown in Fig. 2, and then when the sleeve 5 is held against movement the shaft is, through the action of the intermediate gears, arranged in the interior of the head, as in the common form of reversing tap-holder referred to, and shown in said patent, giving a movement in a direction opposite to the direction of rotation of the head,

so that while the spindle continues to rotate in the same direction the tool will be rotated in the reverse direction.

5 Connected with the collar 10, that is borne by the moving shaft 7, is a bar 12. The bar preferably has one end forked and is so located that the ends of the fork loosely engage a groove in the collar. With this connection when the collar is moved longitudinally the bar is moved with it, but the bar, which does not rotate, will not interfere with the free rotation of the collar.

10 Connected with the bar 12 is a rod 13, that bears a block or dog 14. Nuts 15 are preferably used to secure the rod to the bar, so that the rod may be adjusted lengthwise to regulate the distance between the bar that engages the collar on the tool-holder shaft and the dog which is held by the rod. One end of the rod is loosely supported in a perforation in an arm 16, that is clamped to the sleeve 1 or other stationary part of the machine. In a perforation in this arm 16 is supported a post 17, which post is held in position by a set-screw 18, which can be loosened for permitting of an adjustment of the post and then set for clamping the post in that position. On the end of the post is a trip or foot 19, that is arranged to project into the path of the stock being operated upon. Preferably this foot is perforated and the tool is passed through the perforation, as shown in the views.

30 On the sleeve 5 is a block or stud 20. This block is located so that when the dog is in one position the block will revolve with the sleeve freely; but when the dog is in another position the block will engage the dog, so that the block and sleeve cannot revolve. With the tool-holding shaft thrust into the head and the clutch-pins on the head and collar on the shaft in engagement, so that the spindle, head, sleeve, and tool-holding shaft with the tool all rotate in one direction, as shown in Fig. 1, the dog 14 is in such a position that the block 20 during revolution passes free from the dog. When the tool-holding shaft is drawn out of the head and the clutch-pins are disengaged, as shown in Fig. 2, the collar on the tool-holding shaft is drawn away from the head and this draws the dog on the rod connected with the collar into the path of the block on the sleeve, so that the block makes contact and is held against rotation by the dog.

55 As above described, with the sleeve held against rotation as it will be with the block engaging the dog and the clutch-pins disengaged, the tool-holding shaft will be rotated in an opposite direction from the rotation of the head. Thus the spindle will continue to rotate in the same direction while the direction of rotation of the tool will be reversed.

60 When a tap or other tool is started into a piece of work, the pressure on the end of the tool, whether the tool is fed to the work or the work fed to the tool, forces the tool-hold-

ing shaft into the head, so that the clutch-pins engage, as shown in Fig. 1, and the tap rotates forward with the live-spindle of the machine. When the tap has fed into the work the proper predetermined distance, according to the adjustment of the foot or trip, and the face of the work makes contact with the trip, the continued rotation of the tap, as the work cannot feed further on the tap on account of the trip, causes the holding-shaft to be drawn out of the head and the clutch-pins disengaged, which, as previously described, also draws the dog into the path of the block on the sleeve, so that the sleeve will be held against rotation, and then the tap immediately begins to rotate in a reverse direction through the mechanism referred to and turns itself out of the work. The dog-rod is so attached to the bar connected with the tool-holding-shaft collar that the distance between the collar and the dog can be readily and nicely adjusted, insuring that the dog engages the block on the sleeve at the proper time, and the trip is readily adjusted, so that the depth of entrance of the tap into the work can be accurately regulated.

By means of this device a perforation can be tapped to any desired predetermined depth and then the tap reversed automatically, so that it will withdraw from the threaded hole, and the outward movement is preferably much more rapid than the inward.

The device is very simple, it is easily adjusted, it operates automatically, and it can be used in connection with a lathe or with a drill-press, drilling-machine, or other boring or perforating machine arranged to feed the tool to the work or the work moved to the tool, either vertically or horizontally, the only change necessary being the shape of the clamping part which holds the arm 16.

I claim as my invention—

1. In combination in a reversing tool-holder, a head adapted to be connected to and to rotate in the same direction with a live-spindle, a tool-holder movably supported by the head, clutch mechanisms for joining the tool-holder with the head so that they rotate in the same direction when the tool-holder is in one position, reversing mechanisms for rotating the tool-holder in the opposite direction when the clutch mechanisms are disengaged, and a dog connected to and movable with the tool-holder and adapted to travel into or out of the path of a part of the reversing mechanisms according to the position of the tool-holder, substantially as specified.

2. In combination in a reversing tool-holder, a head adapted to be connected to and to rotate in the same direction with a live-spindle, a tool-holder movably supported by the head, clutch mechanisms for joining the tool-holder with the head so that they rotate in the same direction when the tool-holder is in one position, reversing mechanisms for rotating the tool-holder in the opposite direction when the clutch mechanisms are disengaged, a dog con-

5 nected to and movable with the tool-holder  
and adapted to travel into or out of the path  
of a part of the reversing mechanisms accord-  
ing to the position of the tool-holder, and a  
trip device adapted to engage the work so as  
to cause the tool-holder to draw the dog into  
position to engage a part of the reversing  
mechanisms, substantially as specified.

10 3. In combination in a reversing tool-holder,  
a head having a shank adapted to be con-  
nected to and to rotate in the same direction  
with a live-spindle, a shaft bearing a tool-  
chuck and a collar, movably supported by the  
head, clutch mechanisms for joining the col-  
lar with the head so they rotate in the same  
15 direction when the shaft is in its inner posi-  
tion, reversing mechanisms supported by the

head for rotating the shaft in the opposite di-  
rection when the clutch mechanisms are dis-  
engaged, a dog adjustably supported by a rod 20  
that is loosely connected with the collar on  
the shaft, a sleeve on the head connected with  
the reversing mechanisms, a block on the  
sleeve adapted to make contact with the dog  
when the clutch mechanisms are disengaged, 25  
and a tripping-foot borne by a post adjust-  
ably supported by an arm adapted to be con-  
nected with a stationary part of the machine  
with which the device is to be used, substan-  
tially as specified.

ALANSON D. QUINT.

Witnesses:

H. R. WILLIAMS,  
E. J. HYDE.